

LYNX

OUTDOOR KITCHEN

COLLECTION

DRAWER CABINETS

18" AND 24" WIDTHS

Smart storage meets rugged design in these functional cabinets, crafted to keep tools, accessories, and ingredients close at hand. Their form and finish complete the outdoor kitchen experience.



FEATURES

- Heavy-gauge 304 stainless steel
- Weather-seal cabinet gaskets
- Refined powdercoat finishes
- Soft-close technology
- Adjustable feet
- Seamless appliance integration

MODELS

- **LYNX-3D-18**
18" 3-Drawer Base
- **LYNX-3D-24**
24" 3-Drawer Base

EXCLUSIVE COLOR FINISHES

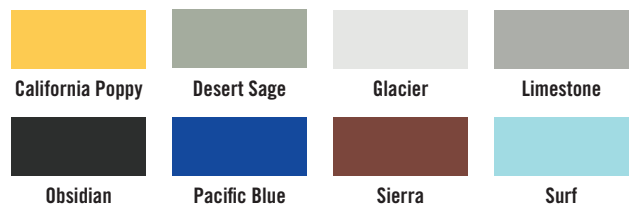

STAINLESS STEEL FINISH



FINISH STYLING OPTIONS

- ANVIL - Brushed Stainless Steel
- SWATCH - Brushed Stainless Steel Interiors and Powder Coated Exteriors
- PULSE - Powder Coated Interiors and Exteriors

FEET STYLING OPTIONS

- RISE - A floating installation approach with panels lifted 3" off the ground, creating an elevated, airy look. Designed to adapt to natural grade shifts, this style delivers a modern edge with functional flexibility across varied terrain.
- FITTED - A grounded installation method where panels drop flush to the surface and connect with a seamless toe kick. Ideal for flat, level environments, this technique offers a monolithic and tailored aesthetic.

LYNX

OUTDOOR KITCHEN

COLLECTION

DRAWER CABINETS

28" DEPTH

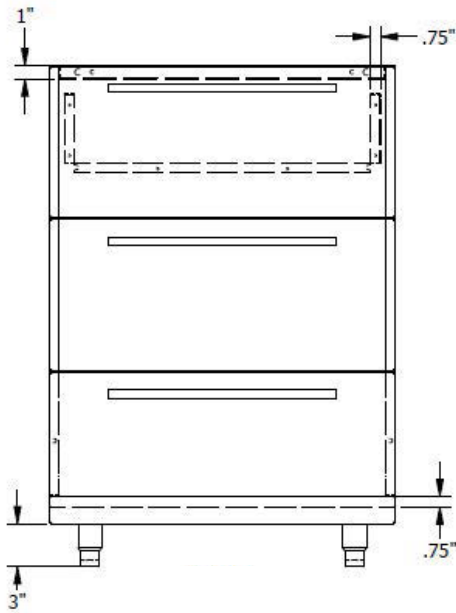

FRONT

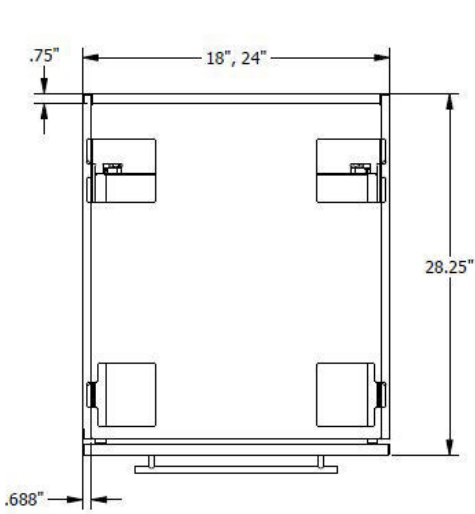
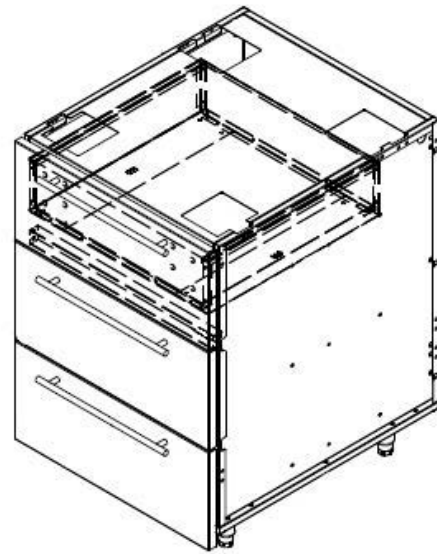

TOP

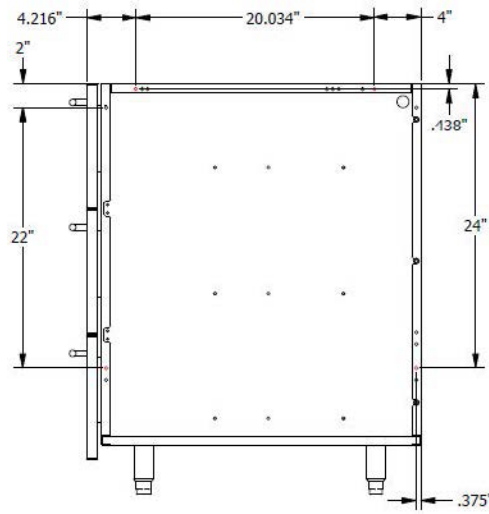

SIDE

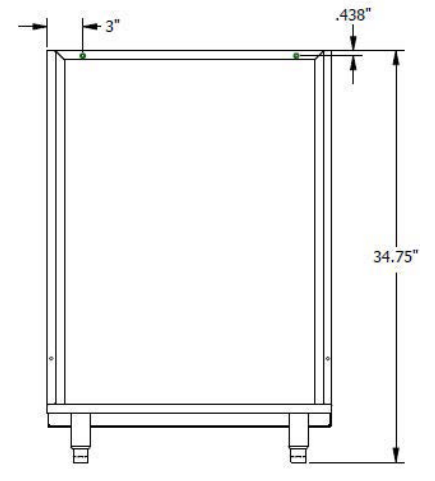

REAR